

# CX-3<sup>®</sup> Gas Saw OWNER'S MANUAL

MODELS	PART #
CX-3 <sup>®</sup> Honda GX160	159345



Revision 113	03.2019
Manual Part# 159345-OM	

**Caution:** Read all safety and operating instructions before using this equipment. This owner's manual **MUST** accompany the equipment at all times.

## INTRODUCTION

Congratulations on your purchase of a CX-3® Concrete Saw. We are certain that you will be pleased with your purchase. MK Diamond takes pride in producing the finest construction power tools and diamond blades in the industry.

Operated correctly, your CX-3® Concrete Saw should provide you with years of service. In order to help you, we have included this manual. This owners manual contains information necessary to operate and maintain your CX-3® Concrete Saw safely and correctly. Please take the time to familiarize yourself with the CX-3® Concrete Saw by reading and reviewing this manual.

Read and follow all safety, operating and maintenance instructions.

If you should have questions concerning your CX-3® Concrete Saw, please feel free to call our friendly customer service department at: 800 421-5830

Regards,

MK Diamond

### NOTE THIS INFORMATION FOR FUTURE USE:

<b>MODEL NUMBER:</b>	
<b>SERIAL NUMBER:</b>	
<b>PURCHASE PLACE:</b>	
<b>PURCHASE DATE:</b>	

**WARRANTY:** For your (1) one year warranty to be effective, complete the online Product Registration as soon as possible. Visit [www.mkdiamond.com/registration/](http://www.mkdiamond.com/registration/)

## TABLE OF CONTENTS

### **SAFETY**

Safety Messages	4
Damage Prevention Message	4
General Safety Precautions and Hazard Symbols	5
California Proposition 65 Message	8
Prestart Safety	9
Safety Label Locations	10
Product Specifications	11

### **UNPACKING, TRANSPORT and ASSEMBLY**

Unpacking	12
Contents	12
Transport	13
Assembly	14-15

### **STARTUP, OPERATION and SHUTDOWN**

Startup	16-17
Operation	18
Shutdown	19
Cleanup	20

### **MAINTENANCE AND TROUBLESHOOTING**

Maintenance	21-31
-------------	-------

### **THEORY**

Theory Of Diamond Blades	32
--------------------------	----

### **ACCESSORIES ORDERING and RETURN INSTRUCTIONS**

Accessories	33
Ordering Information	34
Return Material Policy	34
Packaging Instructions	34
Authorized Service Centers	34
Warranty	35

Read and follow all safety, operating and maintenance instructions. Failure to read and follow these instructions could result in injury or death to you or others. Failure to read and follow these instructions could also result in damage and/or reduced equipment life. Safety warnings and guidelines do not by themselves eliminate danger. They are not substitutes for proper accident prevention procedures and good judgement.

### SAFETY MESSAGES

A safety message alerts you to potential hazards that could hurt you or others. Each safety message is preceded by a safety alert symbol (  ) and one of three words: **DANGER**, **WARNING**, or **CAUTION**.



**DANGER** You **WILL** be **KILLED** or **SERIOUSLY INJURED** if you **DO NOT** follow directions.



**WARNING** You **CAN** be **KILLED** or **SERIOUSLY INJURED** if you **DO NOT** follow directions.



**CAUTION** You **CAN** be **INJURED** if you **DO NOT** follow directions. It may also be used to alert against unsafe practices.

### DAMAGE PREVENTION AND INFORMATION MESSAGES

A Damage Prevention Message is to inform the user of important information and/or instructions that could lead to equipment or other property damage if not followed. Information Messages convey information that pertains to the equipment being used. Each message will be preceded by the word **NOTE**, as in the example below.

**NOTE:** Equipment and/or property damage may result if these instructions are not followed.

### GENERAL SAFETY PRECAUTIONS AND HAZARD SYMBOLS

In order to prevent injury, the following safety precautions and symbols should be followed at all times!



**ALWAYS** read this Owner's Manual before operating the machine. **DO NOT** operate or service this equipment before reading this entire manual. Read and understand all warnings, instructions and controls on the machine. Know how to stop the equipment quickly in case of emergency. It is the operators responsibility to use this machine under safe working conditions and conform with federal, state and local codes or regulations pertaining to safety, air, pollution, noise etc...



**ALWAYS** keep the Blade and Belt Guards in place. **DO NOT** operate this machine with any guard or safety device removed. A Guard, or any damaged part should be repaired or replaced immediately.



**NEVER** operate this equipment without proper protective clothing, shatterproof glasses, steel-toed boots and other protective devices required by the job. Non-slip foot wear is recommended.



### PERSONAL PROTECTIVE EQUIPMENT

**ALWAYS** wear approved respiratory, head, ear and eye protection when operating this machine.



### ACCIDENTAL STARTS!

Before starting the engine/motor, be sure the **ON/OFF** switch is in the **OFF** position to prevent accidental starting. Place the **ON/OFF** switch in the **OFF** position before performing any service operation. **ALWAYS** place the power **ON/OFF** switch in the **OFF** position when the machine is not in use.



### ROTATING PARTS

Keep hands, feet, hair, and clothing away from all moving parts to prevent injury. Never operate the motor with covers, shrouds, or guards, removed.



### HOT PARTS!

Engine components can become extremely hot from operation. To prevent severe burns, do not touch these areas while the engine is running, or immediately after it is turned off. Never operate the engine with heat shields removed.



### OVER SPEED

**NEVER** tamper with the governor components or settings to increase the maximum speed. Severe personal injury and damage to the engine or equipment can result if operated at speeds above maximum.



### ELECTRICAL SHOCK

**NEVER** touch electrical wires or components while the engine is running. Exposed, frayed or worn electrical wiring and plugs can be sources of electrical shock which could cause severe injury or burns. Do not touch the plug with wet hands.



**ALWAYS** avoid inhalation of and skin contact with silica dust and/or mist. Provide proper dust removal. Use dust-collection system when applicable.



**NEVER** operate the machine in an explosive atmosphere or near combustible materials. Sparks from the cutting-action of this machine can ignite flammable materials, liquids, gases or dust.



This equipment should not be operated by persons under 18 years of age.



### KEEP CHILDREN AWAY

All visitors and children should be kept a safe distance from work area. Maintain a safe operating distance to other personnel.



### MAKE THE WORKSHOP KID PROOF

Make the workshops kid proof by using padlocks, master switches or by removing starter keys.



### DO NOT FORCE THE TOOL

A power tool will do a job better and safer operating at the rate for which it was designed. **DO NOT** force a tool or an attachment to do a job that it was not designed to do.

**USE PROPER APPAREL**

**DO NOT** wear loose clothing, gloves, neckties, rings, bracelets, or other jewelry that may be caught in moving parts. Non-slip footwear is recommended. Wear protective hair covering to contain long hair.

**SECURE WORK**

Clamps or a vise should be used to hold work whenever practical. Keeping your hands free to operate a power tool is safer.

**DO NOT OVERREACH**

Keep proper footing and balance at all times by not overreaching.

**DISCONNECT TOOLS**

Power tools should always be disconnected before servicing, adjusting or when changing accessories, such as blades, bits, cutters, and the like.

**MAINTAIN TOOLS WITH CARE**

Keep tools clean and maintained for the best and safest performance. Always follow maintenance instructions and examine the machine before use. If any abnormal vibrations or noises occurs, turn off machine immediately and have the problem corrected before further use.

**REMOVE ADJUSTING KEYS AND WRENCHES**

Form a habit of checking to see that keys and adjusting wrenches are removed from the power tool before it is turned on.

**KEEP WORK AREA CLEAN**

Cluttered work areas and benches invite accidents. Keep area around machine clear of obstructions which could cause persons to fall.

**DO NOT USE IN DANGEROUS PLACES**

**DO NOT** operate equipment in dangerous or hazardous environments. **DO NOT** use power tools in damp or wet locations nor expose them to rain. Always keep the work area well lighted.

**USE RECOMMENDED ACCESSORIES**

Consult the owner's manual for recommended accessories. Using improper accessories may increase the risk of personal or by-stander injury. Unauthorized equipment modifications will void all warranties. Manufacturer does not assume responsibility for any accident due to equipment modifications.



**ALWAYS** ensure that the machine is on level ground before using.

**NEVER STAND ON THE TOOL**

Serious injury could occur if a power tool is tipped, or if a cutting tool is unintentionally contacted.

**TRANSPORT**

When loading or unloading the machine, use caution. Remove the blade prior to hoisting, loading and transporting the machine.

**CHECK FOR DAMAGED PARTS**

Before using a power tool, check for damaged parts. A guard or any other part that is damaged should be carefully checked to determine if it would operate properly and perform its intended function. Always check moving parts for proper alignment or binding. Check for broken parts and mountings and all other conditions that may affect the operation of the power tool. A guard, or any damaged part, should be properly repaired or replaced. Always check the machine for loose bolts before starting.

**DIRECTION OF ROTATION**

A blade or cutter should always be installed so that rotation is in the direction of the arrow imprinted on the side of the blade or cutter. It should correspond with the rotational direction of the motor. Always feed work into a blade against the direction of rotation.

**NEVER LEAVE A TOOL UNATTENDED**

**TURN POWER OFF** - Do not leave a tool until it comes to a complete stop. **ALWAYS** turn a power tool **OFF** when leaving the work area, or, when a cut is finished.



**NEVER** disconnect any "emergency or safety devices". These devices are intended for operator safety. Disconnection of these devices can cause severe injury, bodily harm, or even death! Disconnection of any of these devices will void all warranties. Unauthorized equipment modifications will void all warranties. Manufacturer does not assume responsibility for any accident due to equipment modifications.



**NEVER** use this machine with any cutter designed for woodworking.



**NEVER** operate this equipment when not feeling well due to fatigue, illness or taking medicine.



**NEVER** operate this equipment under the influence of drugs or alcohol.



On belt driven equipment, overtensioning of belts will result in premature crank and/or bearing failure.



Whenever necessary, replace nameplate, operation and safety decals when they become difficult to read.



**ALWAYS** store equipment properly when it is not being used. Equipment should be stored in a clean, dry location out of the reach of children



**DO NOT** lend or rent this equipment without including the Owner's Manual and the Engine/Motor Manufacturer's Manual.



Check the chemical properties of the material to be cut/grinded and follow all EPA/OSHA Regulations. (cut/ground)

## **SILICA DUST WARNING**

---

Grinding/cutting/drilling of masonry, concrete, metal and other materials with silica in their composition may give off dust or mists containing crystalline silica. Silica is a basic component of sand, quartz, brick clay, granite and numerous other minerals and rocks. Repeated and/or substantial inhalation of airborne crystalline silica can cause serious or fatal respiratory diseases, including silicosis. In addition, California and some other authorities have listed respirable crystalline silica as a substance known to cause cancer. When cutting such materials, always follow respiratory precautions.

Use appropriate NIOSH-approved respiratory protection where dust hazard may occur. Paper masks or surgical masks without a NIOSH approval number are not recommended because they do little to protect the worker. For more information about respirator programs, including what respirators have received NIOSH approval as safe and effective, please visit the NIOSH website at:  
<http://www.cdc.gov/niosh/npptl/topics/respirators>

Observe OSHA regulations for respirator use (29 C.F.R. §1910.134 and §1503.1). Visit <http://www.osha.gov> for more information.

## **CALIFORNIA PROPOSITION 65 MESSAGE**

---

Some dust created by power sanding, sawing, grinding, drilling, and other construction activities contain chemicals known (to the State of California) to cause cancer, birth defects or other reproductive harm. Some examples of these chemicals are:

- Lead, from lead-based paints
- Crystalline silica, from bricks and cement and other masonry products
- Arsenic and chromium, from chemically treated lumber

For further information, consult the following sources:  
<http://www.osha.gov/dsg/topics/silicacrystalline/index.html>  
<http://www.cdc.gov/niosh/docs/96-112/>  
<http://oehha.ca.gov/prop65/law/P65law72003.html>  
<http://www.dir.ca.gov/Title8/sub4.html>  
<http://www.P65warnings.ca.gov>

Your risk from these exposures varies depending on how often you do this type of work. To reduce your exposure to these chemicals, work in a well-ventilated area, and work with approved safety equipment, such as dust masks that are specially designed to filter out microscopic particles. Where use of a dust extraction device is possible, it should be used. To achieve a high level of dust collection, use an industrial HEPA vacuum cleaner. Observe OSHA 29 CFR part 1926.57 and 1926.103.



## GAS ENGINE SAFETY

---

Gasoline models are shipped from the factory dry, meaning without fuel or oil. Both must be added before equipment can be used. Check the engine Manufacturer Owner's Manual for instructions on fueling, break-in, servicing and proper engine care and use.

## GAS SAFETY PRECAUTIONS

---



### EXPLOSIVE FUEL!

Gasoline is extremely flammable, its vapors can explode if ignited; store only in approved containers, in well-ventilated, unoccupied buildings and away from sparks or flames. **DO NOT** fill the fuel tank while the engine is running or hot. Spilled fuel could ignite if it contacts hot parts or sparks from ignition. **DO NOT** overfill tank. **DO NOT** start the engine near spilled fuel. Never use gasoline as a cleaning agent.



Refer to engine manufacturer manual for specific operating procedures and safety warnings. **ALWAYS** check the fuel lines and fuel tanks for leaks and cracks before starting the engine. **DO NOT** run the machine if fuel leaks are present or the fuel lines are loose.



Accidental start hazard. Disconnect spark plug prior to servicing.



### LETHAL EXHAUST GASES!

Engine exhaust gasses contain poisonous carbon monoxide (an odorless, colorless gas). Avoid inhaling exhaust fumes Breathing it can cause unconsciousness and even kill you. Always operate gasoline engine machines in a well-ventilated area. **DO NOT** operate in areas where exhaust fumes could accumulate without wearing appropriate respiratory protection. Never run the engine in a closed building or confined area.

**NOTE:** Prior to operation of this machine the operator must determine the existence and location of any subsurface features that may be hazardous or could damage the equipment, (i.e. electric cable, natural gas line etc.).

## FUELING SAFETY

---

**ALWAYS** use caution when handling fuel. Shut off the engine and allow to cool before refueling.



**ALWAYS** refill fuel tank in a well-ventilated area.



**ALWAYS** replace the fuel tank cap after refueling.



**ALWAYS** close fuel valve on engines when machine is not being operated.

Move the machine at least 10 feet (3 meters) from the fueling point before starting the engine, and make sure the gas cap is on the machine and the fuel can is properly tightened.

**OPERATION & SAFETY DECALS**

The CX-3® Concrete Saw is equipped with a number of safety decals. These decals are provided for operator safety and maintenance information. Should any of these operation or safety decals become unreadable, replacements can be obtained by calling (800) 262-1575.

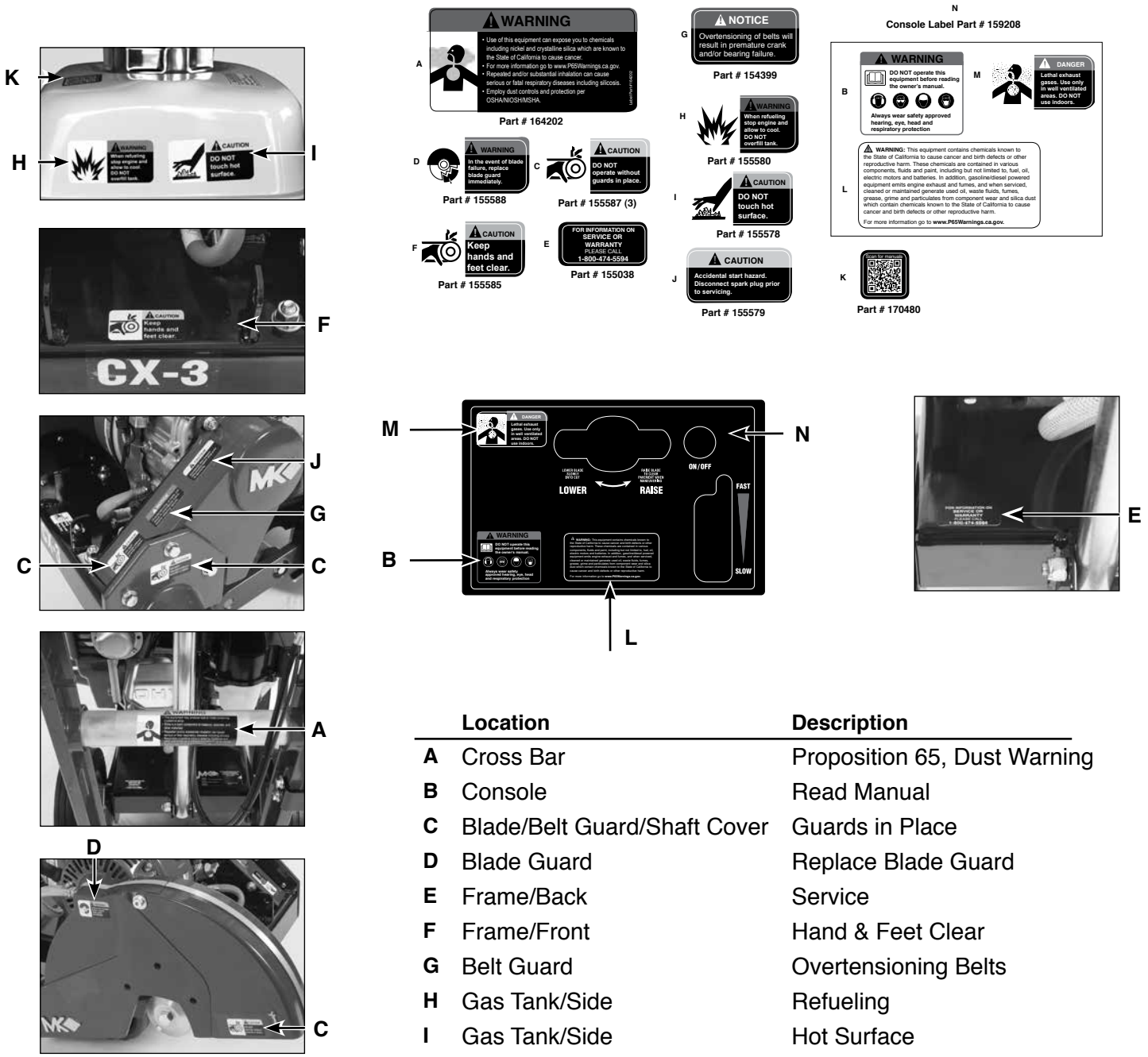

Location	Description
A Cross Bar	Proposition 65, Dust Warning
B Console	Read Manual
C Blade/Belt Guard/Shaft Cover	Guards in Place
D Blade Guard	Replace Blade Guard
E Frame/Back	Service
F Frame/Front	Hand & Feet Clear
G Belt Guard	Overtensioning Belts
H Gas Tank/Side	Refueling
I Gas Tank/Side	Hot Surface
J Belt Guard	Accidental Start
K Gas Tank/Top	QR Code Manuals
L Console	Prop 65
M Gas Tank/Side	Lethal Exhaust
N Console	Prop 65/Machinery Hazard

## PRODUCT SPECIFICATIONS

---

The CX-3® is a versatile gas powered Concrete Saw. Operated and used according to this manual, the CX-3® will provide years of dependable service.

### General Description

The CX-3® is engineered as a portable concrete saw powered by a Honda gas engine. The saw is capable of cutting up to five and half (5-1/2) inches in depth.

### Motor and Weight Specifications

Motor and Weight specifications for the CX-3® are listed below.

<b>Model</b>	<b>CX-3® Honda</b>
<b>Engine</b>	Honda (Gas)
<b>Power</b>	GX160 Cyclone
<b>Starter</b>	Electric
<b>Fuel Capacity</b>	.8 Gallon (3.1 Liter)
<b>Blade Capacity</b>	14"
<b>Blade RPM</b>	3,600
<b>Depth of Cut</b>	5-1/2" (140 mm)
<b>Weight</b>	116 lbs. (53 kg)
<b>Part #</b>	159345

### Blade

The CX-3® uses a 12 to 14 inch diameter diamond blade.

### Concrete Saw Usage

The CX-3® is designed to cut various grades of concrete surfaces.

### Features

- Compact, lightweight, engineered for maneuverability and reliability
- Can be used for wet or dry cutting
- Corrosion resistant cast-aluminum blade guard
- Built-in water distribution system supplies water to both sides of blade
- Blade guard mounts on either left- or right-hand side of saw and cuts within 1" of wall or curb
- Sturdy single piece steel motor mount weldment to minimize vibration
- 1" diameter blade shaft with self aligning bearings
- Hinged blade guard provides easy access for blade changes and inspection
- Folding handle bar for compact transport
- Poly V-belt for positive power transmission







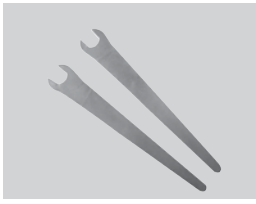

**UNPACKING**

Your CX-3® has been shipped from the factory thoroughly inspected. Only minimal assembly is required.

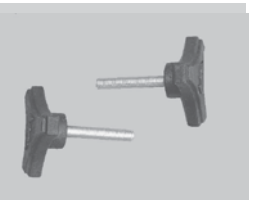
Remove the CX-3® from the pallet and place it on a flat surface.

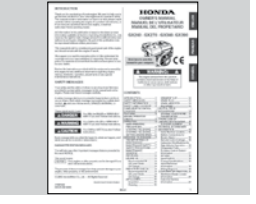
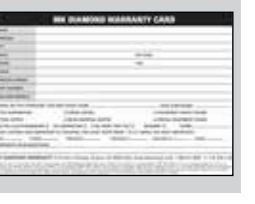
**CONTENTS**

In the containers, you will find one (1) CX-3®, two (2) Blade Shaft Wrenches, one (1) Handlebar, two (2) Handlebar Tri-Knobs, two (2) Tri-Knob Washers, one (1) CX-3® Owner's Manual, one (1) Engine Owners Manual, one (1) Warranty Card, one (1) Handle, and one (1) Pointer.

				
CX-3®	2 Blade Shaft Wrenches	Handlebar	Handlebar Tri-Knob	Tri-Knob Washer
				
CX-3® Owner's Manual	Engine Manual	Warranty Card	Handle	Pointer
				
Crank Wheel				

**TRANSPORT****CAUTION**

1. The CX-3® weighs approximately one hundred and sixteen (116 pounds), use care when transporting.
2. Two people are required to lift and transport the CX-3®.

To lift the CX-3®, one person will lift by grasping the Handlebar and one person will lift by grasping the front of the CX-3®.

Follow the assembly instructions to prepare your CX-3® for operation.

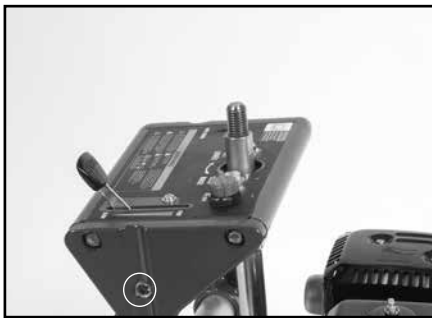
**Handlebar Assembly**

(A)

Locate the threaded holes on both sides of CX-3® console frame.



(B)

Align the handlebar with the threaded holes on the sides of the CX-3® console frame.



(C)

Install one Tri-Knob Washer onto each Tri-Knob. Install Tri-Knobs through the Handlebar and into the threaded holes on the CX-3® console frame.

**Crank Wheel Assembly**

(A)

Thread the crank wheel on to the depth control screw and tighten until snug.



(B)

The crank wheel has a 3/8 - 16 set screw installed.



(C)

Use a 3/16" allen wrench to tighten screw. Do not over tighten as this will cause damage to the crank wheel.

**Diamond Blade Installation**

**NOTE:** When installing the diamond blade retaining-bolt, ensure the threads of the bolt are aligned with the threads of the drive shaft so as not to “cross-thread” the bolt.

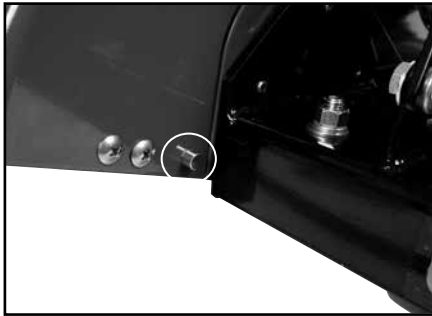

(A)  
Locate Blade Guard lock.

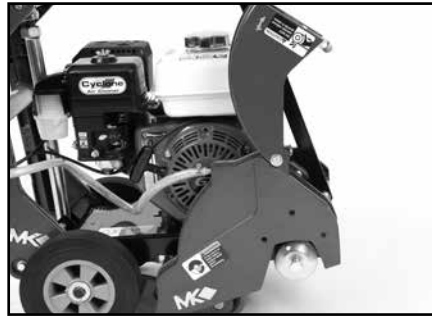

(B)  
Push Lock Button. Open the Blade Guard cover.

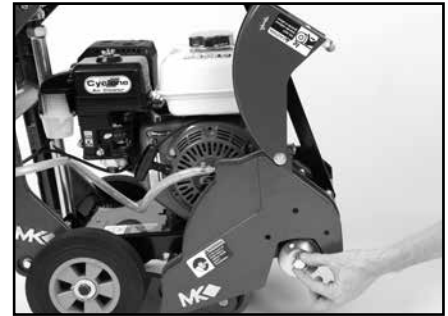

(C)  
Locate the Blade Retaining Bolt and the Outer Flange.



(D)  
Loosen the Blade Retaining Bolt while holding the Shaft Wrench steady. Remove the Blade Retaining Screw and Outer Flange.

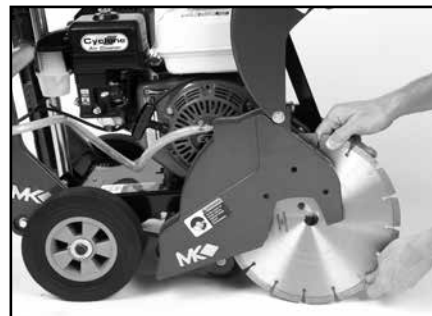

(E)  
Install the Diamond Blade onto the Blade Shaft. Ensure arrow is pointed in direction of rotation.

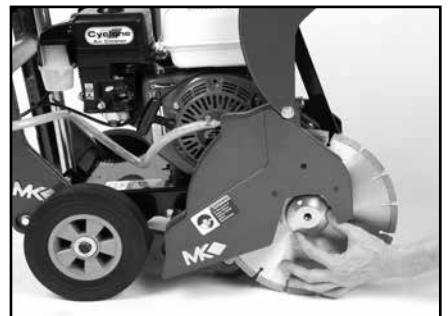

(F)  
Install the Outer Flange. Verify it is seated against the blade.



(G)  
Install the Blade Retaining Bolt.

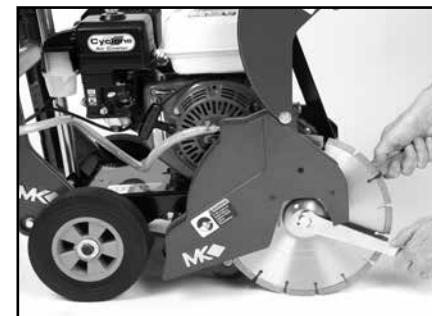

(H)  
Tighten Blade Retaining Bolt while holding the Blade Shaft steady.



**WARNING**

Diamond Blades improperly used are dangerous. Comply with American National Standards Institute Safety Code, B7.1 and, Occupational Safety and Health Act covering Speed, Safety Guards, Flanges, Mounting Procedures, General Operating Rules, Handling, Storage and General Machine Conditions.

## Filling Oil Reservoir

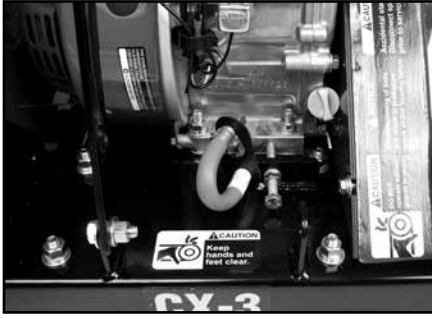

(A)

Verify the Oil Drain Cap is installed onto the Oil Drain Line and is tight. Refer to Engine Manual for details.

**NOTE:** The engine is shipped with no oil in the crankcase. Refer to Engine Manual for details on type and amount of oil required.

## Crank Wheel Handle Installation

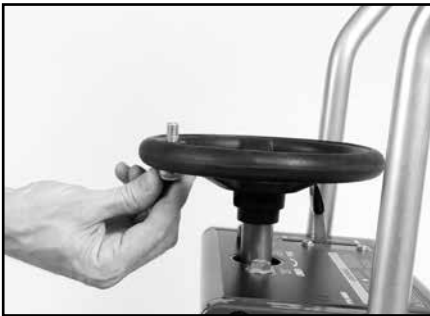

(A)

Insert Crank Wheel Handle mounting bolt up through hole in crank wheel.



(B)

Thread Crank Wheel Handle onto bolt.



(C)

Hold crank wheel handle and tighten bolt with Allen wrench.

## Pointer Installation

**NOTE:** Limiting bracket properly installed will prevent pointer from contacting engine when in the up position



(A)

Insert bolt on Pointer into mounting flange next to Blade Guard.



(B)

Install limiting bracket onto bolt as shown.



(C)

Thread locking nut on to bolt and tighten.

## Filling Fuel Tank



- WARNING**
1. Gasoline is highly flammable and explosive. You can be burned or seriously injured when handling fuel.
  2. To fuel, stop engine if running, and allow it to cool.
  3. Refuel in a well-ventilated area.
  4. Keep gasoline away from appliance pilot lights, barbeques, electric appliances, power tools, etc.
  5. Wipe up spills immediately.

- NOTE:**
1. Fuel can damage paint and plastic. Be careful not to spill fuel when filling the fuel tank. Damage caused by spilled fuel IS NOT covered under the warranty.
  2. DO NOT use stale or contaminated gasoline, or an oil/gasoline mixture.



(A)

Remove the Fuel Cap. Refer to Engine Manual for details.

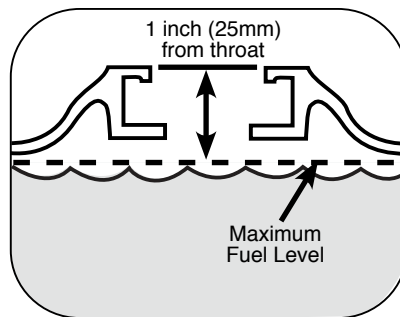

(B)

Ensure fuel level is 1" below the throat of the Fuel Tank.

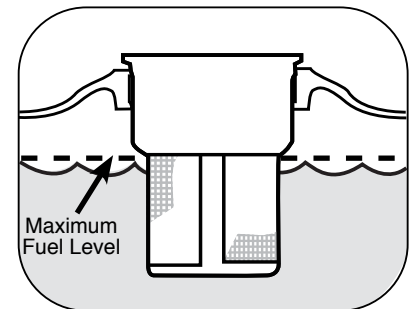

(C)

Ensure fuel level is below the top of the strainer filter.

## Pre-Start Inspection

The pre-start inspection should be performed before beginning any job. If Diamond Blade is worn, replace the blade before starting work.

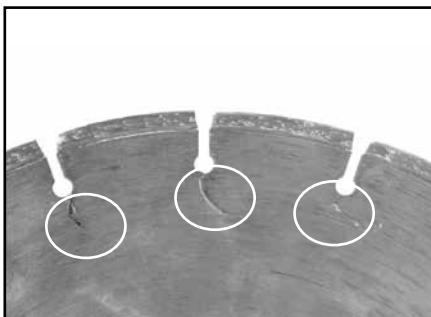

(A)

Inspect Blade for damage for cracks. Verify the Blade is correct for the material being cut.



(B)

Inspect Engine for leaks.



(C)

Inspect the CX-3® for general damage and/or loose hardware.



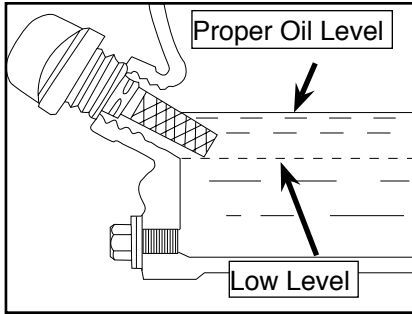

(D)

Check for proper oil level. Refer to Engine Manual for details.

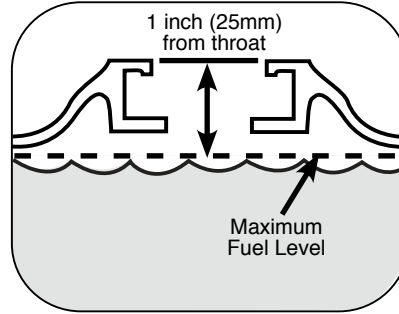

(E)

Ensure fuel level is 1" below the throat of the Fuel Tank.

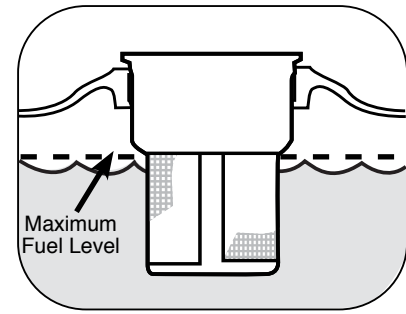

(F)

Ensure fuel level is below the top of the strainer filter.



(G)

Check the Air Filter for cleanliness. Refer to Engine Manual for details.

## Engine Start



**WARNING**

1. Carbon monoxide gas is toxic, breathing it can cause unconsciousness and/or death.
2. Avoid any areas or actions that expose you to carbon monoxide.



(A)

Use the Depth Control Wheel to raise the Blade clear of the floor. Refer to Engine Manual for starting procedure.

**NOTE:**

The operator must be aware of the machine's capabilities and limitations. It is the operators responsibility to use this machine under safe working conditions and conform with federal, state and local codes or regulations pertaining to safety, air, pollution, noise etc...

Prior to operation of this machine the operator must determine the existence and location of any subsurface features that may be hazardous or could damage the equipment, (i.e. electric cable, natural gas line etc.)

## Standard Operation

The following is a brief overview of operating the CX-3®.



(A)

Use the depth control wheel to raise the blade clear of the floor.

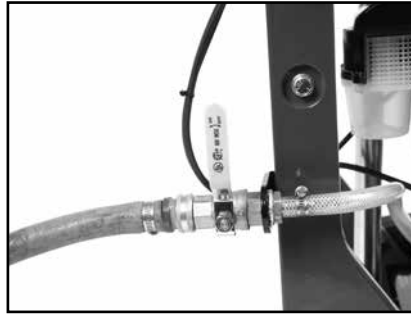

(B)

Attach the cooling supply hose to the Cooling Inlet.

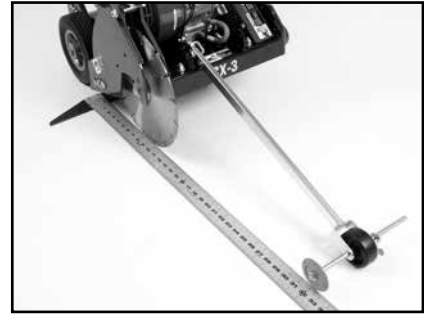

(C)

Lower the Pointer. Align a straight-edge with a blade. Loosen thumbscrew on front of Pointer to adjust guide wheel, align with straightedge.



(D)

Tighten thumbscrew.



(E)

Layout and mark the area to be cut using a chalk-line. Align Pointer and Blade to chalk-line.

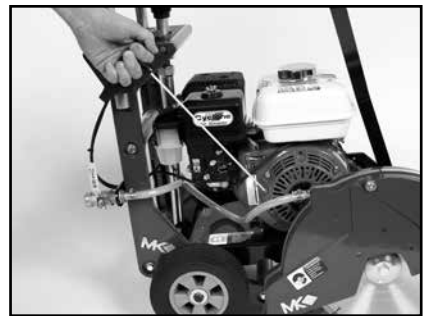

(F)

Start the CX-3® using the Engine Start procedure in the Engine Manual.



(H)

Open Cooling Supply Valve. Verify proper cooling flow and adjust the water flow on the Blade to a desired amount.



(I)

Cut with the engine at full throttle. Slowly lower the Blade until the desired level is reached and begin the cut.



(J)

When the cut is complete, raise the Blade. Close Cooling Supply Valve and shut down saw.

**NOTE:**

Perform the cut using only enough pressure to follow the original marked line. The saw has a natural tendency to pull towards the side on which the blade is mounted. To assure straight line cutting, apply pressure to the appropriate handle. If excessive pressure is required back off the on the forward speed of the saw. Driving the saw too fast while cutting may cause the front wheels to lift causing the blade to cut at uneven depths. Do not attempt to steer the saw. Sudden and severe corrections can cause the blade to be damaged or broken.

### Normal Engine Shutdown

---



(A)

Raise the Blade off the ground.



(B)

Move the Throttle Lever to lower blade speed.



(C)

Place Engine Master Switch in the OFF position. Place Fuel Valve in the OFF position. Refer to Engine Manual.



(D)

Raise the Pointer.

**Emergency Engine Shutdown**



(A)

Place Engine Master Switch in the OFF position.



(B)

Move the Throttle Lever to lower blade speed. Place Fuel Valve in the OFF position.

**Cleanup**



**CAUTION**

Engine parts are extremely hot following use, allow engine to cool 1/2-hour before cleaning. Use care during cleanup to avoid injury.

**NOTE:**

1. To extend operating life, the Concrete Saw should be cleaned following every use.
2. Using a garden hose or pressure washer is not advised as it can force water into the air cleaner or muffler opening.
3. Use care when cleaning around electrical components.



(A)

Verify the engine is off and cool before beginning to clean. Clean the CX-3® with soap and water.



(B)

Clean around the Console.

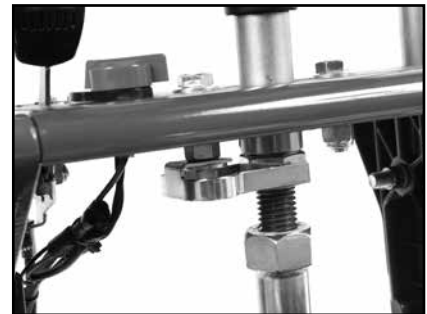

(C)

Clean the Depth Control Screw.

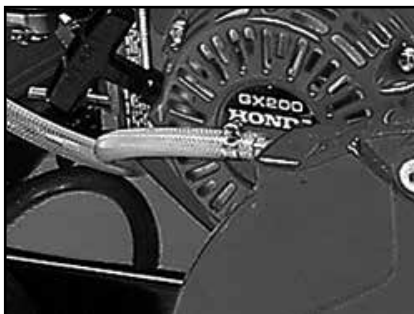

(D)

Clean water system outlets, including water tubes in blade guard.



(E)

Clean the remainder of the exterior surface (except the engine).

**MAINTENANCE SAFETY**

- **NEVER** lubricate components or attempt service on a running machine.
- Keep the machinery in proper running condition.
- Fix damage to the machine immediately and always replace broken parts, or missing decals.

**New Maintenance**

Perform the following after initial purchase and operation of the saw.



(A)

Change engine oil after first month or first 20 operating hours (See Engine Manual).

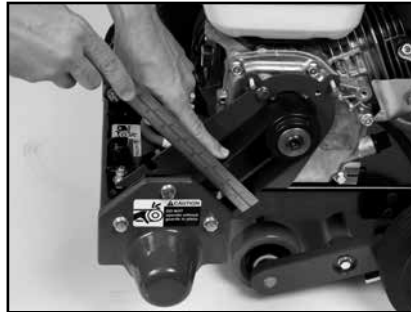

(B)

Check and adjust tension on all belts following first 48 hours of operation (See belt section).

**Maintenance Following Use**

The following maintenance should be performed following each use.



(A)

Shut down the Engine.



(B)

Check Air Filter (See Engine Manual).



(C)

Lubricate the Grease Fitting.

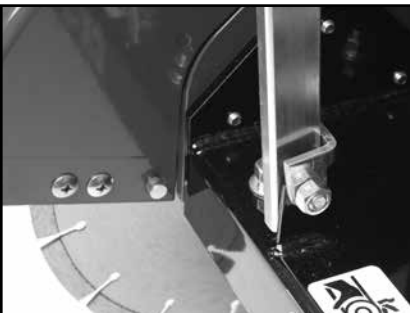

(D)

Lubricate the pivot point of the Pointer.



(E)

Lubricate the Cooling Supply Valve.



(F)

Verify the tightness of all bolts and screws.

**Weekly (50 hours) and Monthly (200 hours)**

The following should be performed monthly. Items should be lubricated using waterproof grease.



(A)

Change engine oil every 100 hours. Refer to Engine Manual for details.

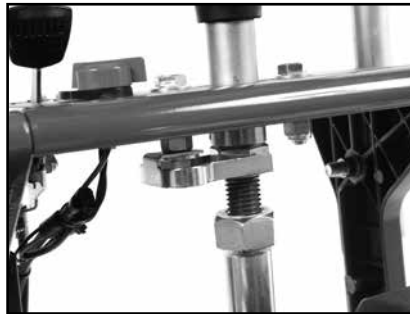

(B)

Lubricate the Depth Control Screw (Monthly).

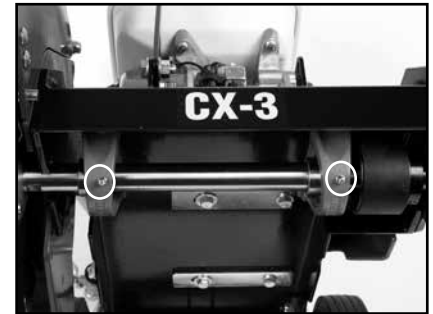

(C)

Lubricate the Blade Shaft Bearings (Monthly).



(D)

Clean engine Air Filter weekly and replace monthly. Refer to Engine Manual for details.



(E)

Clean Spark Plug Weekly and readjust Spark Plug monthly. Refer to Engine Manual for details.

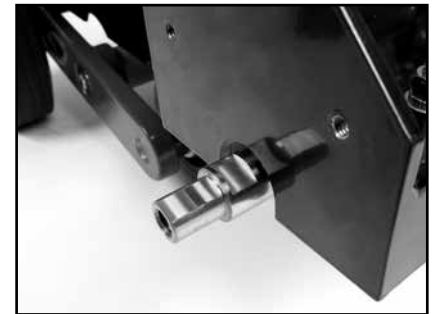

(F)

Clean and lubricate the Blade Shaft.



(G)

Clean and lubricate the Blade Retaining Bolt.

### 500 Hours and 1000 Hour Maintenance

---

Perform the following maintenance every 500 hours.



(A)

Replace Spark Plug. Refer to Engine Manual for details.



(B)

Have Authorized Repair Shop perform 500-hour maintenance.



(C)

Have Authorized Repair Shop perform 1000-hour maintenance.

### Yearly and Two-Year Maintenance

---

Perform the following maintenance every year.

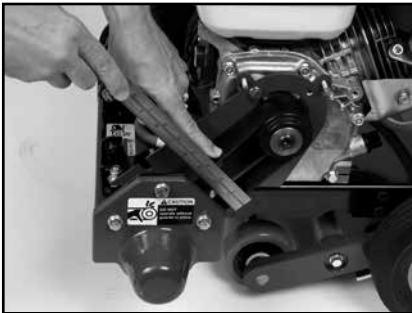

(A)

Inspect belts for proper tension and wear.

## Check Fuel Level

For all Engine related maintenance and troubleshooting refer to the Engine Manual.



### WARNING

1. Gasoline is highly flammable and explosive. You can be burned or seriously injured when handling fuel.
2. To fuel, stop engine if running and allow it to cool.
3. Refuel in a well-ventilated area.
4. Keep gasoline away from appliance pilot lights, barbeques, electric appliances, power tools, etc.
5. Wipe up spills immediately.

### NOTE:

1. Fuel can damage paint and plastic. Be careful not to spill fuel when filling the fuel tank. Damage caused by spilled fuel IS NOT covered under the warranty.
2. DO NOT use stale or contaminated gasoline or an oil/gasoline mixture.



(A)

Remove the Fuel Cap. Refer to Engine Manual for details.

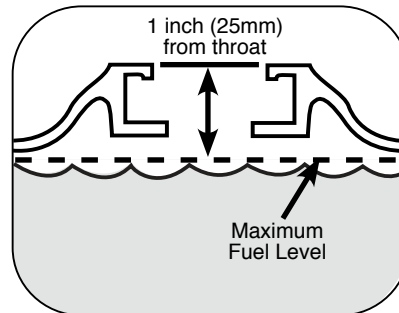

(B)

Ensure fuel level is 1" below the throat of the Fuel Tank.

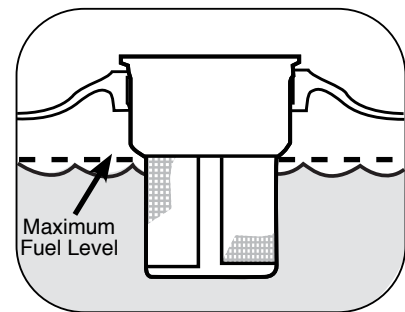

(C)

Ensure fuel level is below the top of the strainer filter.

## Checking Oil Level

### NOTE:

When installing the Oil Dipstick, ensure the threads are aligned with the threads of the Oil Reservoir so as not to "cross-thread."



(A)

Verify the Engine is upright and level. Refer to Engine Manual for details.



## Changing Oil

For all Engine related maintenance and troubleshooting refer to the Engine Manual.  
Oil is a major factor affecting performance and service life.

- NOTE:**
1. Drain used oil when the engine is warm.
  2. Conform to Federal, State, and Local laws, codes and ordinances relative to environmental protection for oil disposal.



(A)  
Remove the Diamond Blade.  
See Blade removal section.



(B)  
Lower the CX-3® to its lowest  
position.



(C)  
Free the Oil Drain Line.  
Place a catch basin below the  
Oil Drain Line. Remove the Drain  
Cap to drain oil completely. Refer  
to Engine Manual for details.

## Engine Air Filter Inspection Cleaning and Replacement

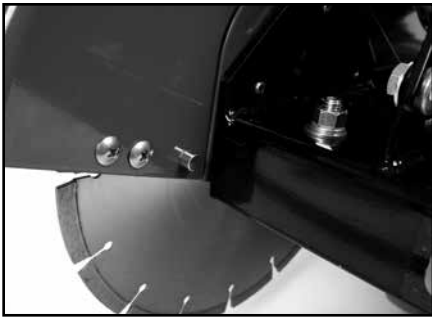

(A)  
Clean the Air Filter. Refer to  
Engine Manual for details.

**Diamond Blade Removal**

(A)  
Locate Blade Guard lock.

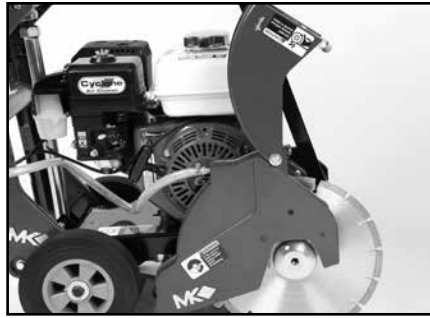

(B)  
Push Lock Button. Open the  
Blade Guard Cover.



(C)  
Remove the Blade Retaining Bolt  
and the Outer Flange.

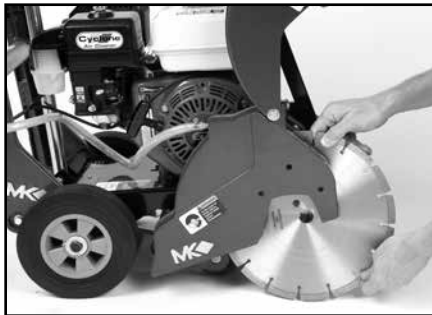

(D)  
Remove blade.

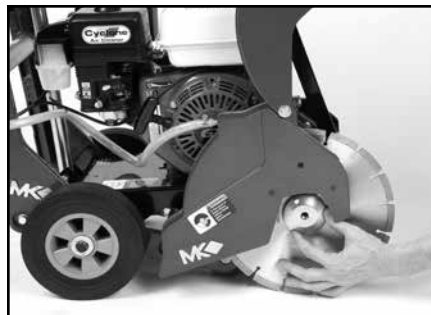

(E)  
Install the new Blade, Retaining  
Bolt and Outer Flange.



(F)  
Tighten Blade Retaining Bolt  
while holding the Blade Shaft  
steady.

## Spark Plug Adjustments and Replacement

For all Engine related maintenance and troubleshooting refer to the Engine Manual.

**⚠ CAUTION** DO NOT work around the engine while hot.



(A)

When installing the Spark Plug, ensure the threads are aligned with the threads in the engine so as not to “cross-thread” the plug.

## Handlebar Repositioning for Storage



(A)

Loosen the Tri-Knobs on both sides of the Handlebar.



(B)

Pivot the Handlebar in the forward direction towards the motor. Tighten the Tri-Knobs on both sides of the Handlebar.

## Blade Repositioning



(A)

Removal Diamond Blade.



(B)

Remove the Cooling Transfer Hose from the Blade Guard.



(C)

Remove the Inner Blade Flange.

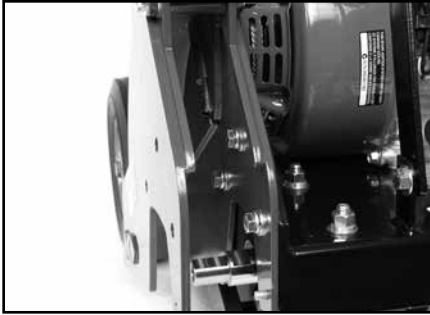

(D)  
Locate the three Blade Guard Retaining Bolts.



(E)  
Remove the Blade Guard Retaining Bolts and remove the Blade Guard.

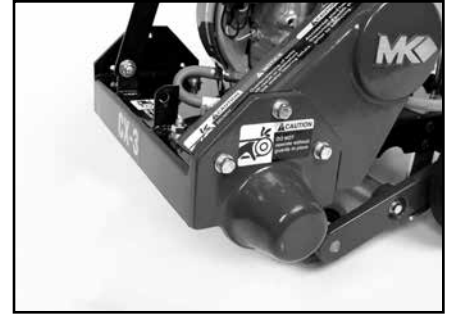

(F)  
Locate the Blade Shaft Cover Retaining Bolts.



(G)  
Remove the Blade Shaft Cover Retaining Bolts and the Blade Shaft Cover.

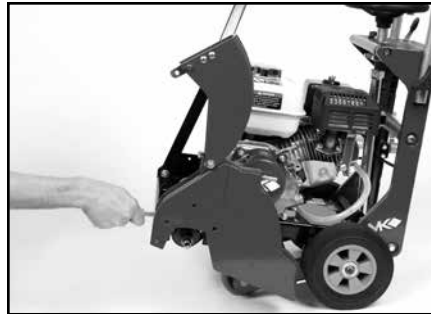

(H)  
Install the Blade Guard on the opposite side.



(I)  
Install the Inner Blade Flange, Blade, Outer Flange and Blade Retaining Bolt.

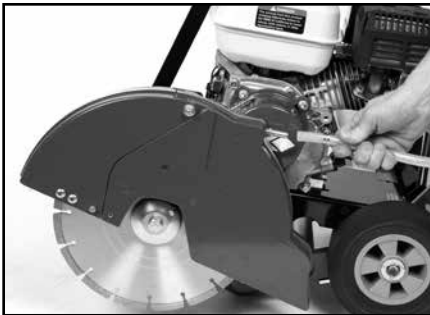

(J)  
Install the Cooling Transfer Hose from the Blade Guard.



(K)  
Install the Blade Shaft Cover.



(L)  
Remove the Pointer.



(M)

Install the Pointer on the opposite side, next to Blade Guard.

### Belt Adjustment and Replacement

In order to ensure the CX-3® operates at peak efficiency, the power transmission belt should be inspected monthly and changed if any signs of damage and/or excessive wear is observed.

**NOTE:** 1. When a new belt is installed, it should be inspected and retensioned after the first forty-eight (48) hours of operation.

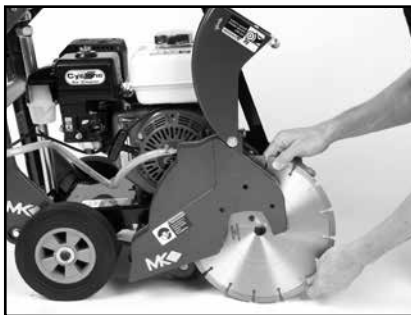

(A)

Remove the Blade Guard (See Blade Removal section).



(B)

Locate and remove the Belt Guard Retaining Bolts and then remove the Belt Guard.



(C)

Inspect the belt for excessive wear, cracks and cuts – if worn, proceed to Step E.



(D)

Check belt for proper tension if tension is correct, go to Step P (Proper tension is approximately 1/8-inch deflection of the belt).



(E)

Locate the four upper Engine Mounting Nuts on both ends of the CX-3® motor and loosen.



(F)

Locate the four lower Engine Mounting Bolts on both ends of the CX-3® motor and loosen.



(G)  
Loosen the Motor Tension Arm. Push the Motor forward to loosen the belt.

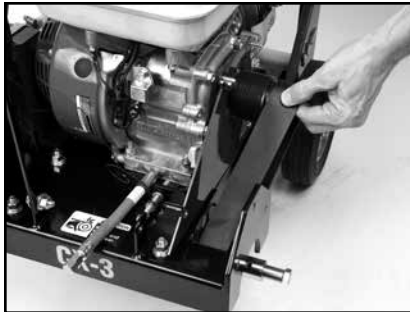

(H)  
Remove the old belt from the Engine and Blade Shaft Pulleys.

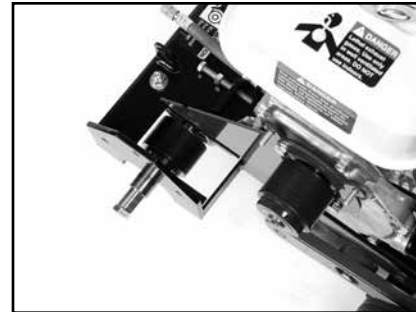

(I)  
Clean and verify the alignment of the Engine and Blade Shaft Pulleys.

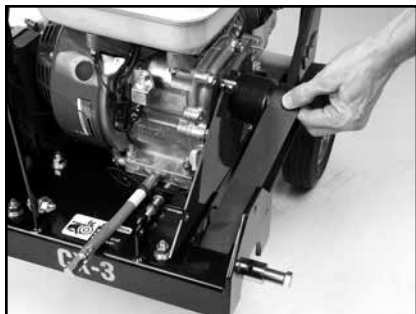

(J)  
Obtain and install a new belt onto the Engine Blade Shaft Pulleys

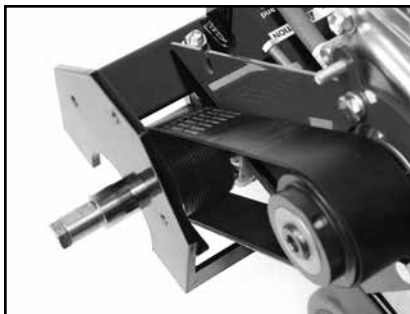

(K)  
Verify the belt is seated in all grooves of the Engine and Cutting Drum Pulleys.



(L)  
Tighten the Motor Tension Arm.

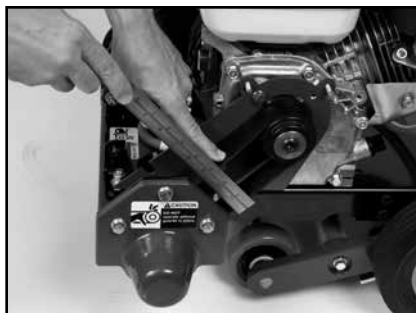

(M)  
Check belt for proper tension (Proper tension is approximately 1/8-inch deflection of the belt).

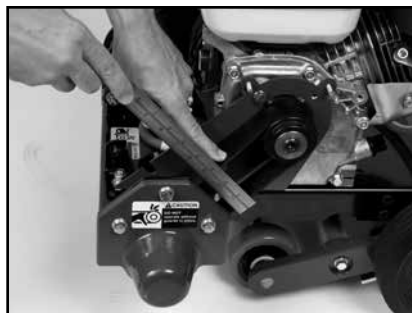

(N)  
Repeat Steps L and M until Proper Tension is achieved.



(O)  
Tighten the Engine Mounting Bolts.



(P)  
Install the Belt Guard and Belt  
Guard Retaining Bolts.



(Q)  
Install the Blade (See Blade  
Installation section).

## THEORY OF DIAMOND BLADES

---

Diamond blades do not really cut; they grind the material through friction. Diamond crystals, often visible at the leading edge and sides of the rim/segment, remove material by scratching out particles of hard, dense materials, or by knocking out larger particles of loosely bonded abrasive material. This process eventually cracks or fractures the diamond particle, breaking it down into smaller pieces. As a result, a diamond blade for cutting soft, abrasive material must have a hard metal matrix composition to resist this erosion long enough for the exposed diamonds to be properly utilized. Conversely, a blade for cutting a hard, non-abrasive material must have a soft bond to ensure that it will erode and expose the diamonds embedded in the matrix. These simple principles are the foundation of “controlled bond erosion”



### Types of Cutting

There are two basic types of cutting-Dry or Wet. The choice of which type of blade to use depends on:

- The requirements of the job
- The machine/tool utilizing the diamond blade
- The preference of the operator





In the case of DRY cutting, the overwhelming popularity and quantity of hand-held saws and the flexible nature of MK Diamond blades to professionally handle most ceramic, masonry, stone and concrete materials, make the DRY cutting blade a very attractive tool. When using a DRY blade, the user must be aware of distinct operating practices to ensure optimum performance. DRY cutting blades require sufficient airflow about the blade to prevent overheating of the steel core. This is best accomplished by shallow, intermittent cuts of the material with periods of “free-spinning” (for several seconds) between each cut, to maximize the cooling process.

For WET cutting applications, MK has the exact blade to compliment both the material to be cut and the wet cutting machine to be used. During cutting operations, liberal amounts of water act as a coolant to support the cutting effectiveness and longevity of the WET blade. Additionally, using water adds to the overall safety of cutting operations by keeping the dust signature down.

Know All You Can About the Material You Wish to Cut



## ACCESSORIES

ITEM	NUMBER	DESCRIPTION	
1	159615	MK – CX10 12" x .100 x 1" Premium Grade for Cured Concrete	
2	159616	MK – CX10 14" x .125 x 1" Premium Grade for Cured Concrete	
3	159617	MK – AX10 12" x .125 x 1" Premium Grade for Asphalt	
4	159618	MK – AX10 14" x .125 x 1" Premium Grade for Asphalt	
5	159619	MK – GX10 12" x .110 x 1" Supreme Grade for Green Concrete	
6	159620	MK – GX10 14" x .110 x 1" Supreme Grade for Green Concrete	
7	166784	Water Tank System	
8	153877	Tachometer	
9	166781	Lifting Bail	

## **ORDERING INFORMATION**

---

You may order MK Diamond products through your local MK Diamond distributor or, you may order direct from MK Diamond.

When ordering direct from MK Diamond, please have the following information ready before calling:

- The Model Number of the saw
- The Serial Number of the saw
- Where the saw was purchased and when
- The Part Number for the part(s) being ordered
- The Part Description for the part(s) being ordered

**NOTE:** Standard orders are \$50.00 or more when ordering direct from MK Diamond. A \$6.00 charge will be added to orders having a net billing value under \$50.00. A nominal handling fee of \$5.00 may apply to some orders.

All parts may be ordered by calling toll free to – 800 421-5830 or 310 539-5221 and asking for Customer Service. For technical questions, call – 800 474-5594.

## **RETURN MATERIALS POLICY**

---

To expedite the service relative to the return of a product purchased through MK Diamond, please observe the following:

**NOTE:** When returning all items, they must have been purchased within the previous twelve (12) months.

- Have the Model Number of the saw
- Have the Serial Number of the saw
- Have the location of where the saw was purchased
- Have the date when the saw was purchased
- Contact Customer Service for approval to return the item(s)
- Obtain a Returned Goods Number (RGA) authorizing the return
- Follow the packaging instructions in the following section
- Ensure the RGA number is on the outside of the returned package
- Ensure your item(s) are prepaid to the destination

For returned items, call toll free to – 800 421-5830 or 310 539-5221 and ask for Customer Service.

## **PACKAGING INSTRUCTIONS**

---

- Remove the Cutting Head and Support Angle Assembly
- Dry the saw before shipping
- When packing, include the following: Saw, Diamond Blade, Blade Guard and Support Angle Assembly and Adjustable Cutting Guide (Other Accessories are not required)
- Package the unit in its original container or one of comparable size (do not ship the unit partially exposed)
- Ensure all parts are secured in the packaging to prevent moving

## **AUTHORIZED SERVICE CENTERS**

---

For quicker repair time, you may contact MK Diamond Customer Service, toll free, at 800 421-5830 or 310 539-5221 for the Authorized Service Center closest to you or visit our web site at [www.mkdiamond.com](http://www.mkdiamond.com). For technical questions, call – 800 474-5594.

**CONTACT**

---

Please contact MK Diamond Products, Inc. Customer Service Department with any questions you might have regarding distributors, parts or service.

Telephone: **(800) 421-5830**

Fax: **(310) 539-5158**

E-mail: **Customer\_Service@MKDiamond.com**

Customer Service Hours: **Monday through Friday, 6AM-4PM PST**

**MK Diamond Products, Inc.**

**1315 Storm Parkway**

**Torrance, CA 90501**

**MK DIAMOND PRODUCTS, INC. LIMITED WARRANTY**

---

MK DIAMOND PRODUCTS, INC. will guarantee every machine they build, to be free from defects in material and workmanship for (1) one year from date of purchase. The obligation of MK DIAMOND PRODUCTS, INC. under this warranty is limited to the repair or replacement of any parts which, under normal use, prove to be defective in material or workmanship. The parts involved or the unit in question should be returned to MK DIAMOND PRODUCTS, INC. or to a point designated by us, transportation prepaid.

This warranty does not obligate us to bear the cost of labor or transportation charges in connection with replacement or repair of defective parts. Likewise, it shall NOT apply to any unit which has been subjected to misuse, neglect or accident. This warranty does NOT apply to any machine which has been repaired or altered outside our factory.

This warranty does NOT obligate MK DIAMOND PRODUCTS, INC., with respect to items not of our manufacture, such as engines, motors, hydraulics, etc., which are subject to their own guarantees and warranties.

We shall in no event be liable for consequential damages or contingent liabilities arising out of failure of any equipment or parts to operate properly.

**WARRANTY:** For your (1) one year warranty to be effective, complete the online Product Registration as soon as possible. Visit **[www.mkdiamond.com/registration](http://www.mkdiamond.com/registration)**

© **COPYRIGHT 2019, MK DIAMOND PRODUCTS, INC. ALL RIGHTS RESERVED.**

The MK Diamond logo is a registered trademark of MK Diamond Products, Inc. and may not be used, reproduced, or altered without written permission. All other trademarks are the property of their respective owners and used with permission.

MK Diamond may have patents, patent applications, trade marks, copyrights of other intellectual property right covering this product in this document.

This manual MUST accompany the equipment at all times. This manual is considered a permanent part of the equipment and should remain with the unit if resold.

The information and specifications included in this publication were in effect at the time of approval for printing.

**CX-3® Concrete Saw**  
OWNERS MANUAL & OPERATING INSTRUCTIONS



**MK Diamond Products, Inc.**

MK Diamond Products, Inc.  
1315 Storm Parkway  
Torrance, CA 90501

Toll-Free: (800) 421-5830  
Phone: (310) 539-5221  
Fax: (310) 539-5158  
[www.mkdiamond.com](http://www.mkdiamond.com)